

ASSEMBLIES LOCATION		
#	E SHEET	ELEVATION
1	E5006	-2.000

SHIPPING MARK	PIECE MARK	QTY.	BILL OF MATERIAL			PAINTING AREA (sq.ft)	TOTAL WEIGHT (Lb)	NOTES
			DESCRIPTION	GRADE	LENGTH			
5099C		1	COLUMN		20'-7 1/4"			
	50094	1	HSS6X6X1/4	A500-GR.B	20'-6 1/2"	39.65	366.31	
	f5015	5	S3L 3/4"Ø	A108	0'-4 3/16"	0.44	2.77	
	f5078	1	L4X4X3/8	A36	0'-6 1/2"	0.76	5.27	
	p5062	1	PL3/8"X7"	A36	1'-0 1/4"	1.29	9.12	
	p5072	1	PL1/4"X7 1/2"	A36	0'-9"	0.99	4.79	
	p5075	1	PL3/8"X9 7/16"	A36	0'-11"	1.54	11.02	
	p5143	1	PL3/8"X12 1/4"	A36	1'-3"	2.52	18.22	
	p5173	1	PL3/4"X12"	A36	1'-0"	2.25	30.63	
	p5384	1	PL1/4"X4"	A36	0'-4"	0.25	1.13	
						49.69	449.26	

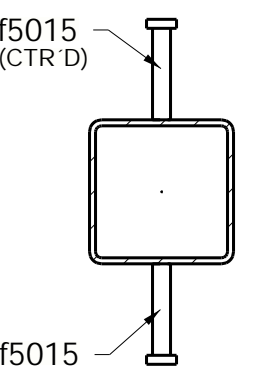
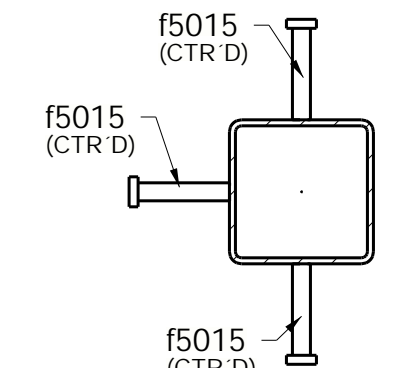
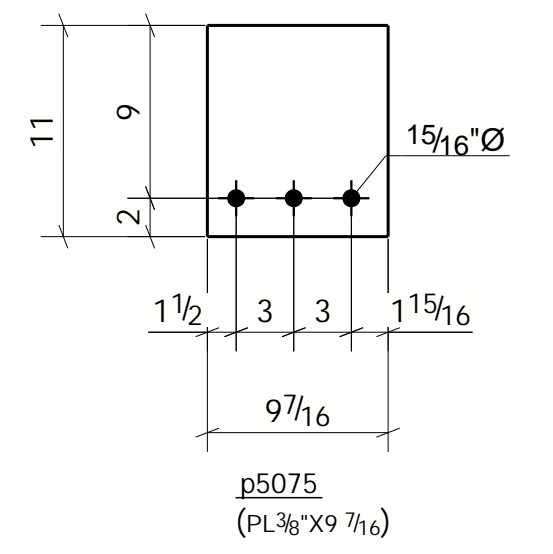
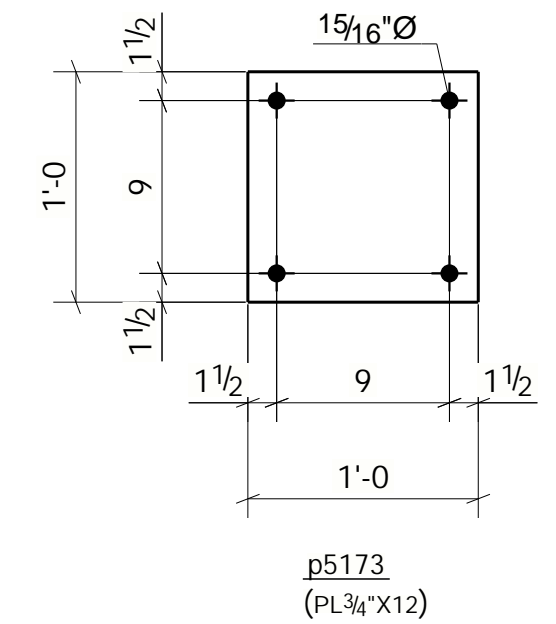
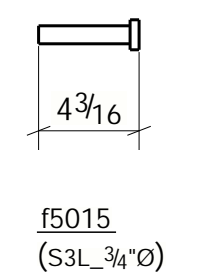
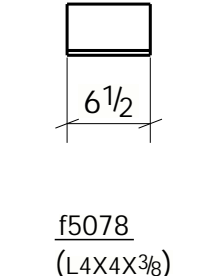
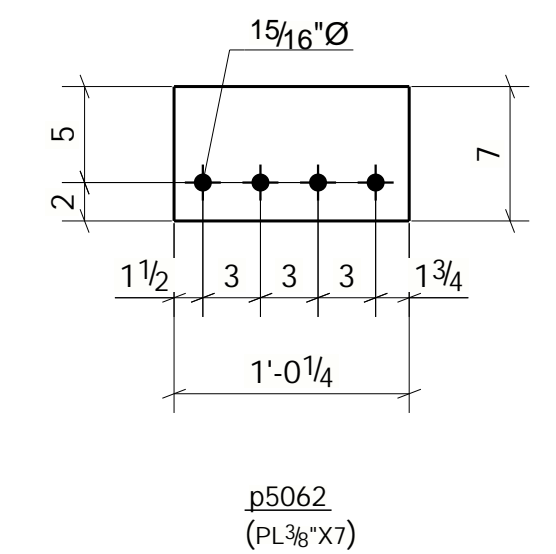
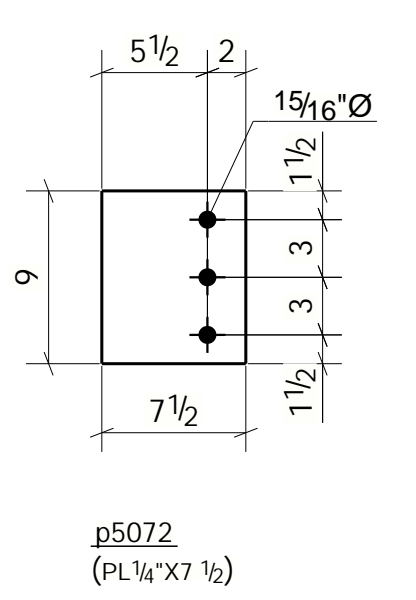
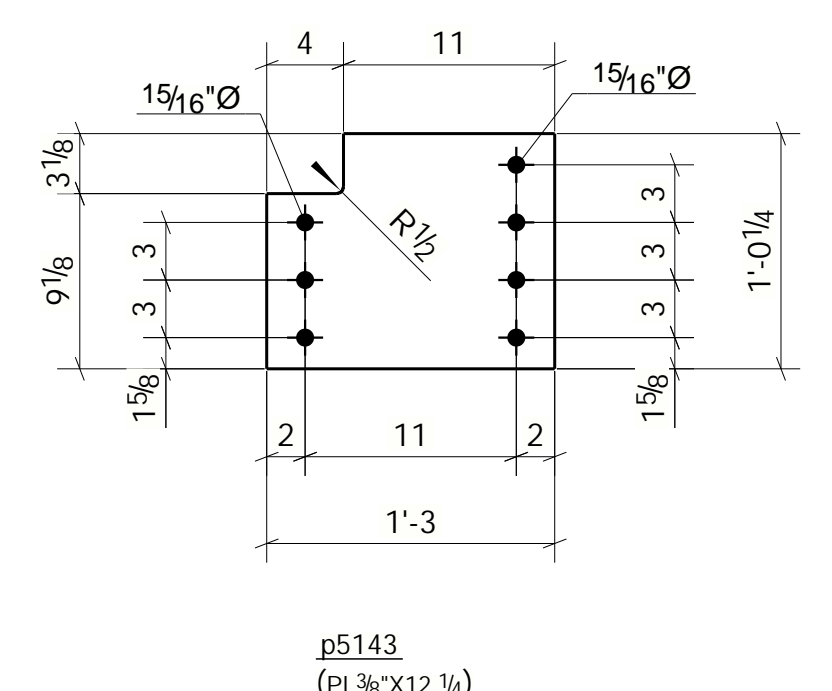
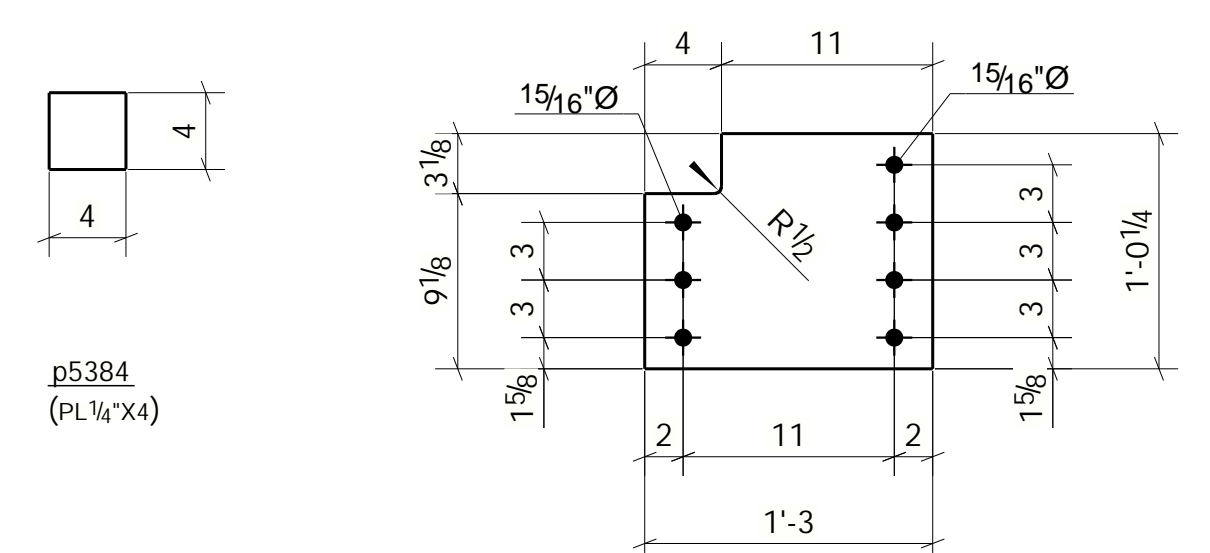
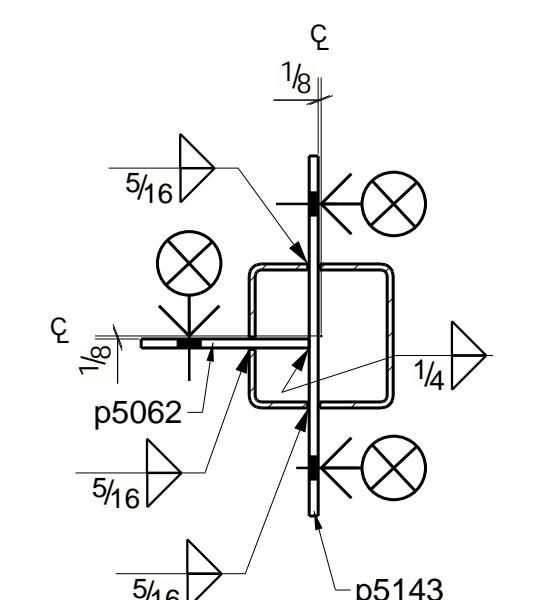
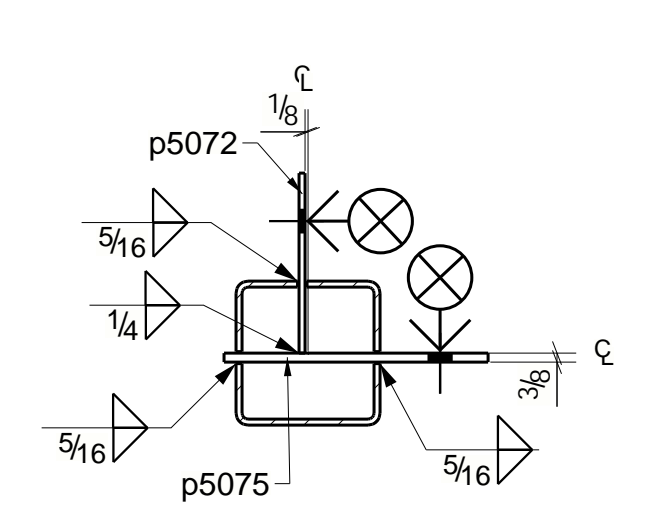
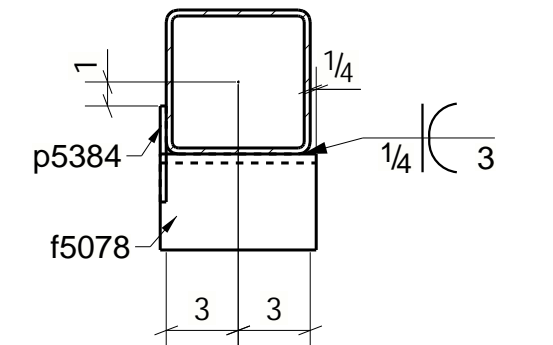
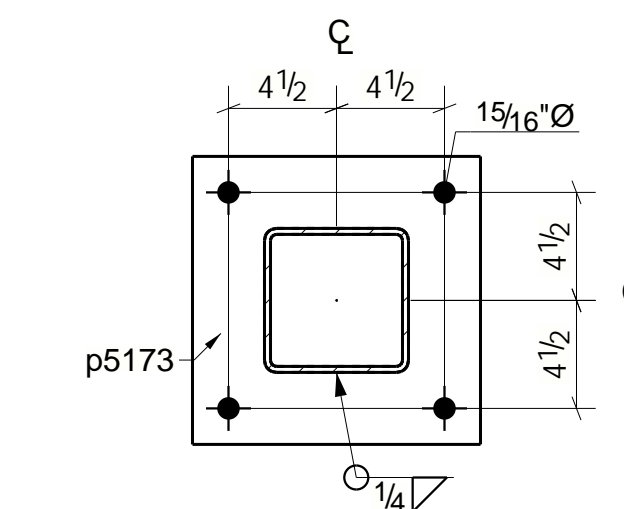
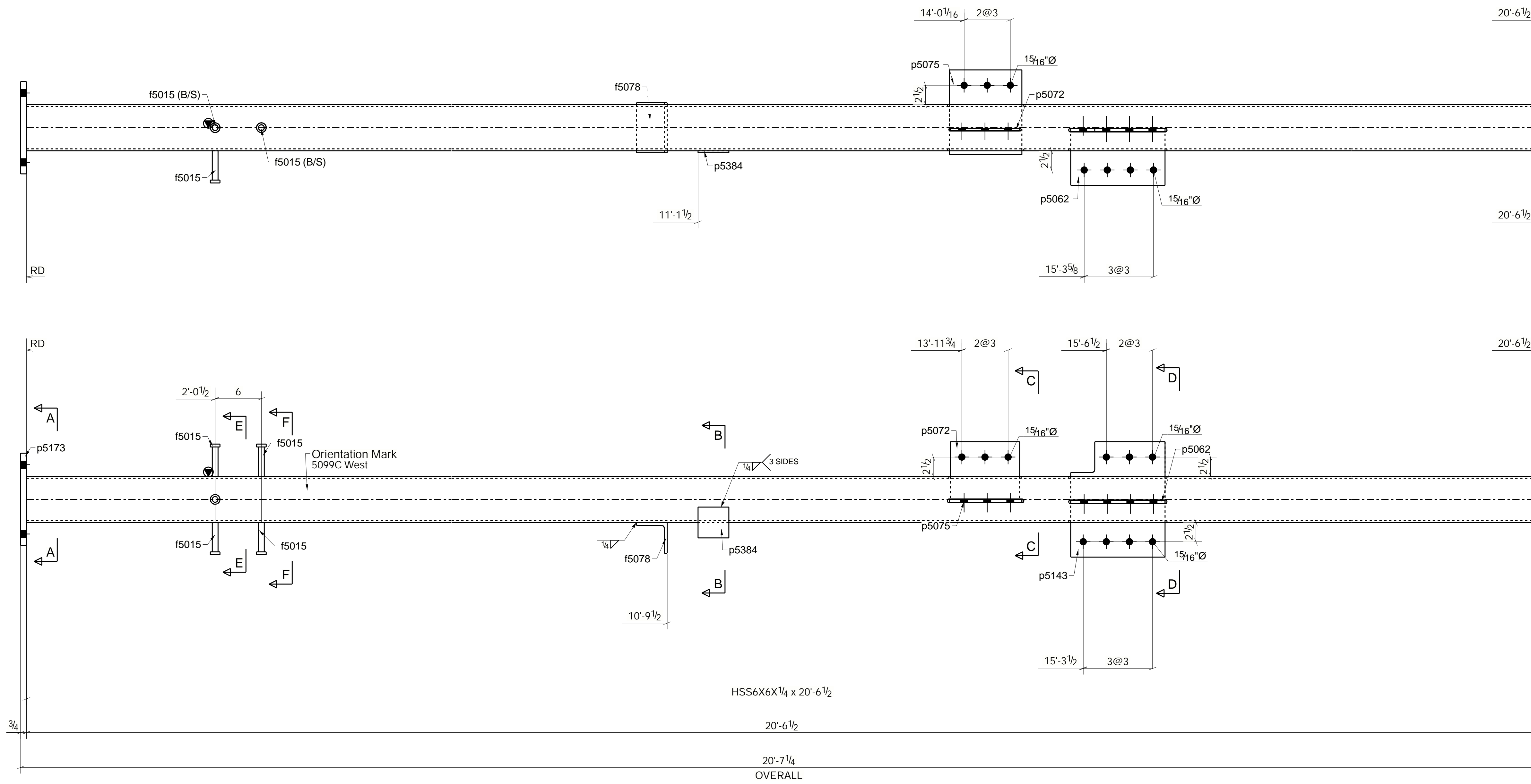

SECTION - E - E

SECTION - F - F

- SYMBOLOLOGY**
- N/S - NEAR SIDE MARK
 - F/S - FAR SIDE MARK
 - B/S - NEAR SIDE BOLT MARK
 - E.I. - EXCEPT INDICATED
 - - NEAR SIDE HOLE
 - ⊖ - FAR SIDE HOLE
 - EL - LEVEL
 - W.P. - WORK POINT
 - CL - CENTER LINE
 - ⊗ - CONNECTING SIDE
 - RD - RUN DIMENSION

ONE - COLUMN - 5099C

REV.	DATE	DESCRIPTION
A		FOR INFORMATION
-		FOR APPROVAL



CUSTOMER LOGOTYPE

NOTES:

REFERENCE DRAWINGS:

PROJECTION:

ISSUE PURPOSE:

- FOR INFORMATION
- PRELIMINARY
- FOR APPROVAL
- FOR FABRICATION
- FINAL
- ASBUILT

THIS CONFIDENTIAL DOCUMENT IS THE PROPERTY OF XXXXX AND SHALL NOT BE GIVEN, COMMUNICATED, COPIED OR REPRODUCED EXCEPT WITH OUR WRITTEN PERMISSION.

PROJECT: AREA: COLUMNS FROM FOOTINGS	DRAWN BY:	REVISED BY:
CLIENT: LOCATION:	ISSUE DATE:	DATE:
DESCRIPTION: COLUMN	ESCALA: NO	PRIORITY: 0
	DRAWING No./DWG No. 5099C	REV. A